

# WARNING BEACOM LED - amber

- 360° homogeneous light distribution

## SPECIFICATIONS:

- Voltage: 10-30V
- Installation: 3 screws on flat base
- Nominal power: 23W
- Approvals: ECE R65 / ECE R10
- Warranty: 3 years
- Ingress protection (IP rating): IP 67
- Operating temperature: -40°C to +65°C
- Connection: cable 500mm

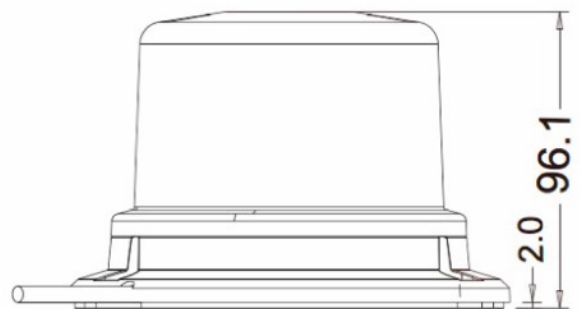
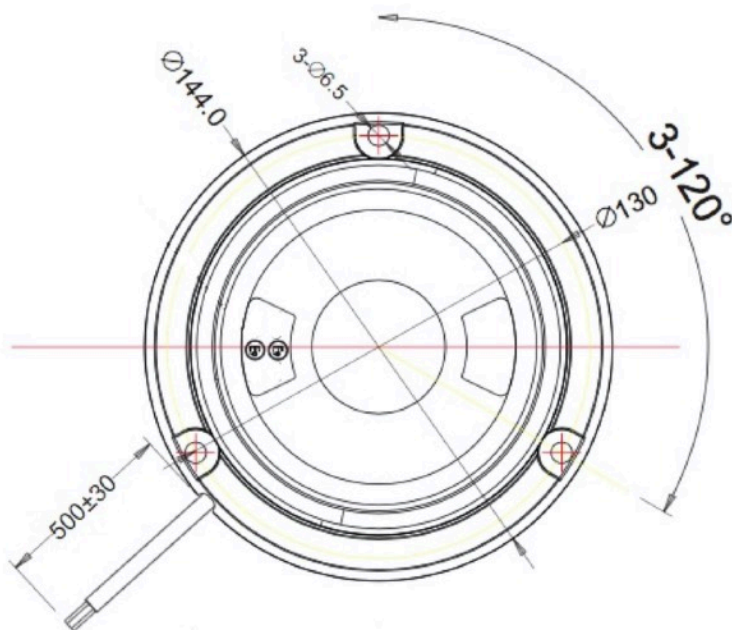
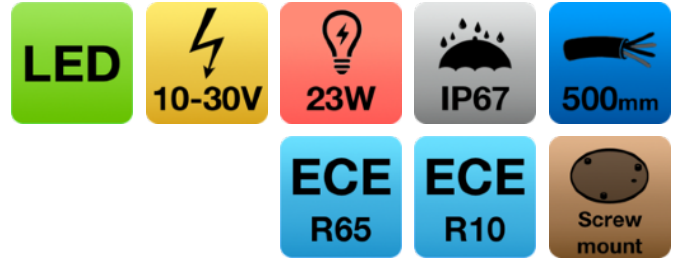

PART NO.	VOLTAGE	NUMBER OF LEDs	INSTALLATION	APPROVALS	IP
<b>EBL509610</b>	10-30V	24x amber LED	3 screws on flat base	ECE R65/R10 (EMC)	IP67