

WARNING BEACON LED - ø115mm

SPECIFICATIONS

- Voltage: 12-24V
- Nominal power: 19W
- Color LED: amber or blue
- Flashing pattern: 3 patterns
- Approval: ECE R65 / ECE R10
- Ingress protection (IP rating): IP 66
- Operating temperature: -30°C to +50°C
- Installation: flat base/screw mount
flex mount
magnetic base

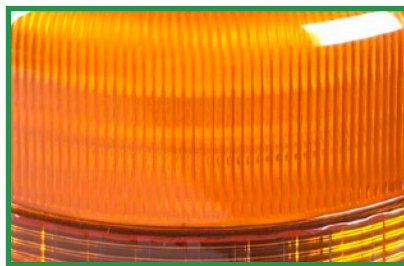

A special, ribbed lens on the inside, for a more even light distribution.



FLAT BASE

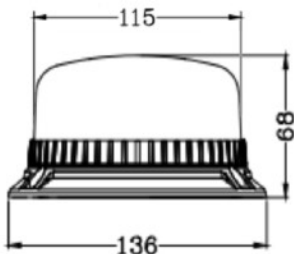

MAGNETIC BASE

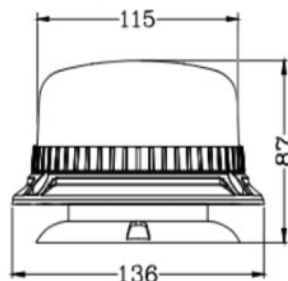

Removable glass with interior switch for changing flash pattern.

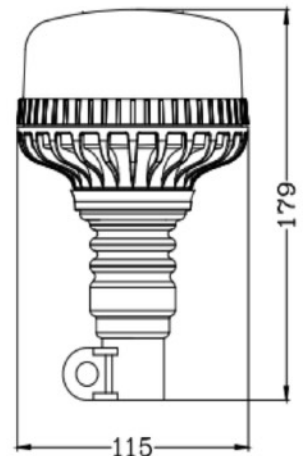

PART NUMBER	COLOR	INSTALLATION	VOLTAGE	LEDs	FLASHING PATTERNS	APPROVAL
EBL60121		FLAT BASE/ SCREW MOUNT	12-24V	19W / 36x LED	SINGLE FLASH DOUBLE FLASH ROTATION	ECE R65 ECE R10
EBL60121B				19W / 12x LED		
EBLF60125		FLEX MOUNT		19W / 36x LED		
EBLF60125B				19W / 12x LED		
EBLM60123				MAGNETIC BASE		